

PETREX[®]-CNT

Pipe systems for petrol stations

Technical details



Contents

CNT 1.0	Contents
CNT 1.10	System description
CNT 1.100	System description PETREX®-CNT
CNT 1.11	Product overview
CNT 1.11.01	Piping, connections, fittings
CNT 1.20	Pipe
CNT 1.20.01	Construction – dimensions, bending radii, weights, volumes
CNT 5.0	Connections
CNT 5.01.15	Connection fitting with split loose flange
CNT 5.01.16	Connection fitting with outer thread
	Fittings
CNT 5.02.04	Through-connection GRAPA – compression/screwed connection CNT
CNT 5.05.01	Steel duct and pipe sleeve entry
CNT 5.52	Fluid mechanics
CNT 5.52.01	Pressure loss diagram for normal and high-octane petrol
CNT 5.52.02	Pressure loss diagram for heating oil (EL) and diesel
CNT 5.55	Tips for laying
CNT 5.55.01	for pressure/suction lines PETREX®-CNT

System description

PETREX®-CNT was specially designed for the underground transport of flammable, water-hazardous fluids on petrol stations. Fast and simple installation with no welded connections, fast completion of work and avoidance of downtime when backfitting are some of the main advantages offered by PETREX-CNT®.

The system advantages of PETREX®-CNT:

- fast and simple laying
- environmentally friendly
- economical
- diffusion-tight

Construction

PETREX®-CNT is a flexible, single-walled pipe system consisting of a corrugated stainless steel inner medium pipe and an outer polyethylene casing. The corrosion-proof stainless steel inner pipe is absolutely permeation-tight and able to fulfil all future requirements for the transport of modern fuels.

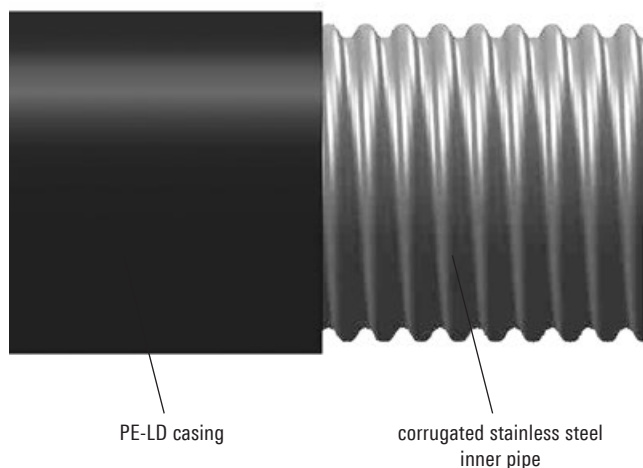

Range of applications

- suction pipe
- vapour recovery stage I / stage II
- vent pipe

The specific applications are subject to the requirements of the regulatory authorities in each country.

Nominal bores and pressure stages

PETREX®-CNT is available in nominal bores from DN 25 / 1" to DN 80 / 3". PETREX®-CNT can be operated with max. –0.7 bar negative pressure or with max. 10 bar positive pressure

Connection fittings

PETREX®-CNT connection fittings can be delivered either as split circular flange or as threaded connector for connection to screwed fittings. Installation is normally carried out without any open flame, i.e. without welding or hard-soldering, using compression fittings.

Accessories

The following accessories are available:





- through-connections
- steel duct entries

Laying the pipes

PETREX®-CNT is manufactured in factory lengths of up to 500 m. The corrugated inner medium pipe ensures excellent flexibility and ease of laying. PETREX®-CNT can be cut to the required length at the construction site and, where necessary, bent through tight radii.

Product overview

Piping/connection fittings/moulded fittings

Type designation	Type CNT	Nominal bore/ connection DN	Pressure PN	Connection type	Material No.	Work- sheet
Pipe 	30/ 39	25		corrugated inner pipe	1.4404	CNT 1.20.01
	39/ 49	32		PE-LD outer casing		
	48/ 60	40				
	60/ 71	50				
	98/120	80				
Connection fitting with split loose flange 	39/ 49	32	10	split loose flange	steel	CNT 5.01.15
	48/ 60	40		acc. to DIN EN 1092-1	coated	
	60/ 71	50			1.4404/	
	98/120	80/100			1.4301	
Connection fitting 	30/ 39	25	10	outer thread	steel	CNT 5.01.16
	39/ 49	32			coated	
	48/ 60	40			1.4404/	
	60/ 71	50			1.4301	
Through-connection 	30/ 39	25			1.4404/	CNT 5.02.04
	39/ 49	32			1.4571/	
	48/ 60	40			1.4301/	
	60/ 71	50			ECO 51P 6030	
Steel manhole entry 	30/ 39	76.1 x 2.9 mm		pipe sleeve from contractor		CNT 5.05.01
	39/ 49	76.1 x 2.9 mm				
	48/ 60	114.3 x 3.6 mm				
	60/ 71	114.3 x 3.6 mm				
	98/120	168.3 x 4.5 mm				

Product Construction

Dimensions, bending radii, weights, volumes

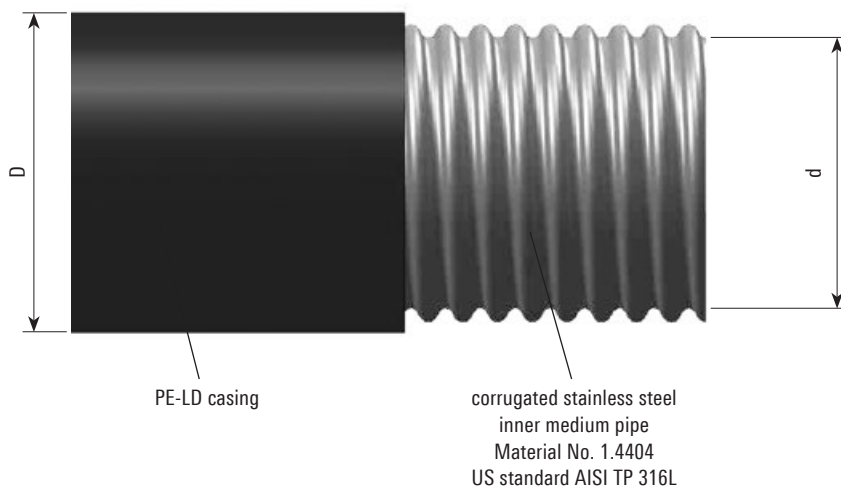

All geometrical data are compiled in the following table.

Type	Nominal bore	Dimension		Bending radius*	Weight kg/m	Volumes dm ³ /m or l/m	Article No.
		d mm	D mm				
CNT 30/ 39	1"	30	39	20	0.56	0.8	1014463
CNT 39/ 49	1 ¼"	32	49	25	0.90	1.3	1014464
CNT 48/ 60	1 ½"	48	60	30	1.37	2.0	1014465
CNT 60/ 71	2"	60	71	40	1.75	3.0	1014466
CNT 98/120	3"	98	120	80	4.50	8.4	1014468

* Only bend the pipe with a bending template/bending machine.

Connection fitting

with split loose flange

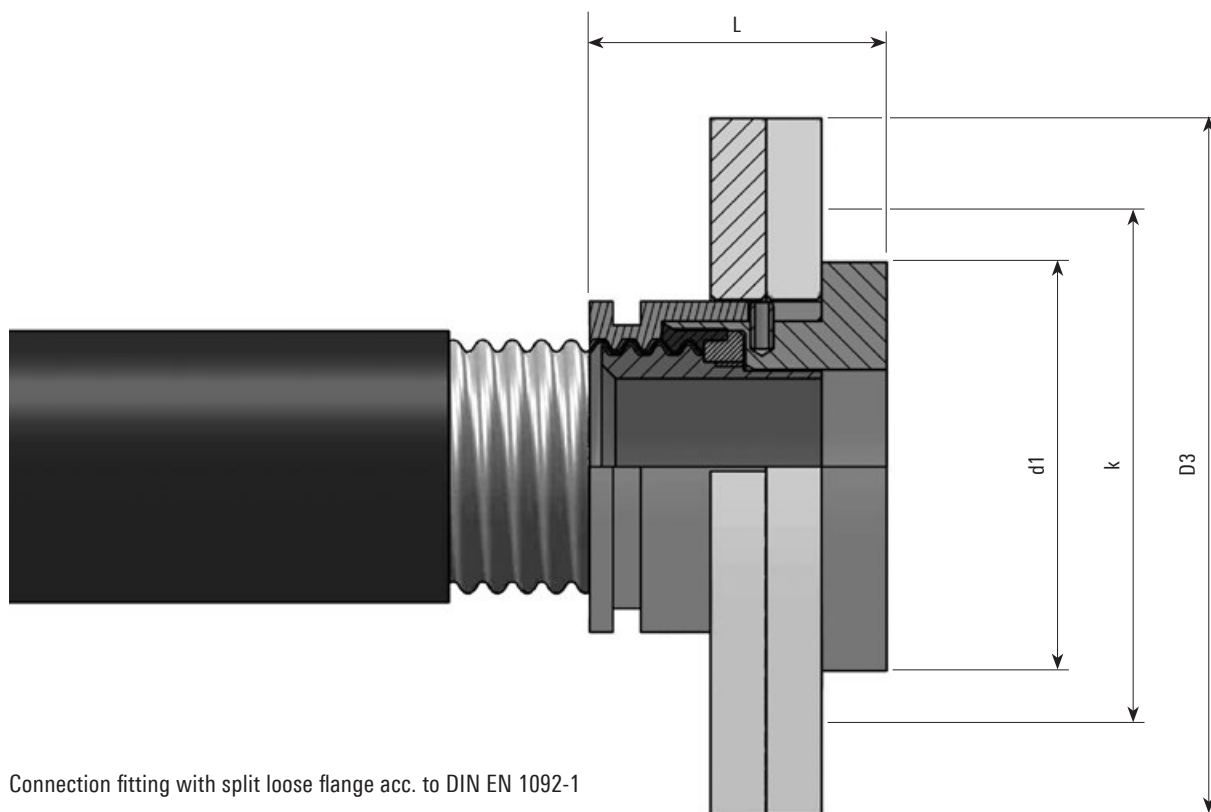

Connection fitting with split loose flange acc. to DIN EN 1092-1

Material:

- Connection piece with collar
- Pressure ring
- Support collar
- Split loose flange
- Inner pipe seal

- Material No. St 52-3 nickel-plated
- Material No. St 52-3 nickel-plated
- Material No. 1.4404
- P265GH/P250GH, galvanized
- Graphite ring

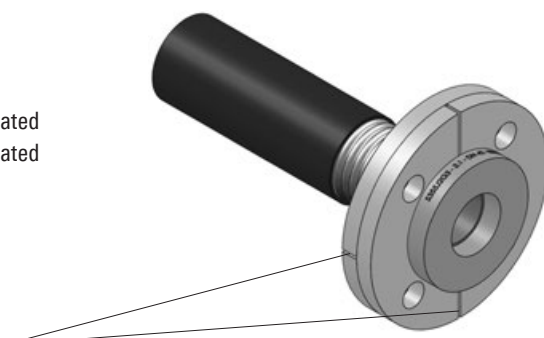

Tip for installing the split loose flange:

Stagger the separation of the loose flanges 90° against each other.

Type	DN	Flange DN	D3	d1	k	L	Screws*	Number	Number of drill holes	Article No. connection fitting
			mm	mm	mm	mm				
CNT 30/ 39	25	25	115	68	85	56	M16 x 80	4	4	1014365
CNT 39/ 49	32	32	140	78	100	52	M16 x 90	4	4	1014649
CNT 48/ 60	40	40	150	88	110	64	M16 x 90	4	4	1014370
CNT 60/ 71	50	50	165	102	125	68	M16 x 90	4	4	1014373
CNT 98/120	80	80/100	220	158	180	91	M20 x 110	8	8	1014376

Connection fitting

with outer thread

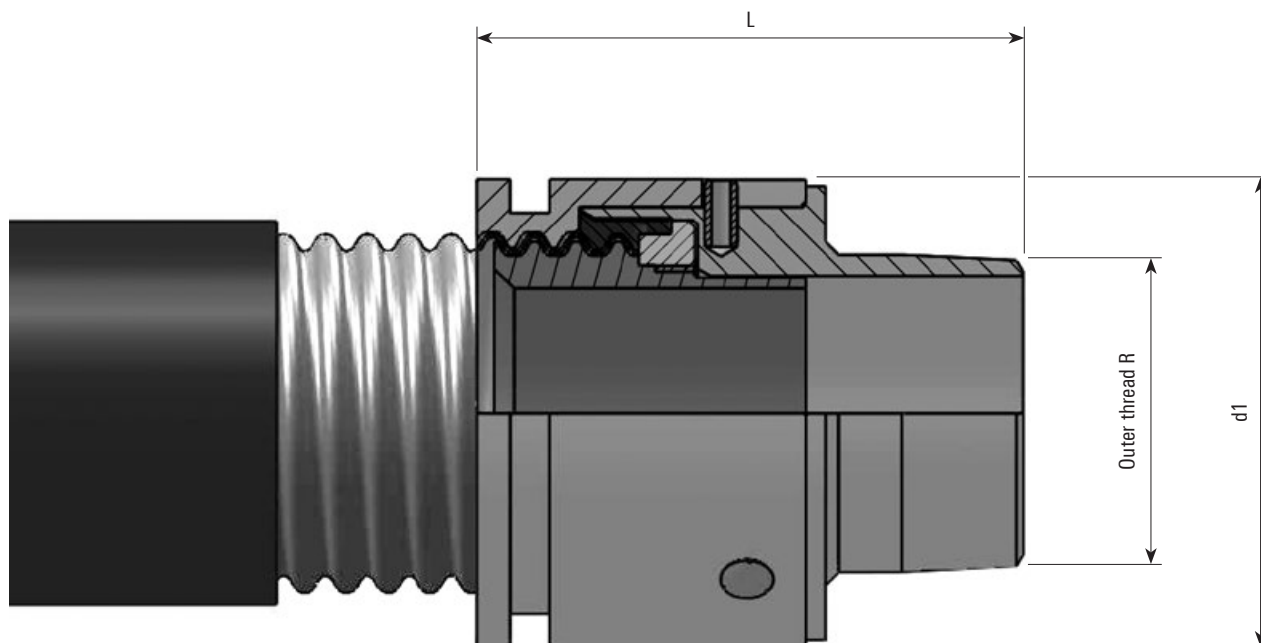

Material:

Connection piece with outer thread

Material No. St 52-3 nickel-plated

Pressure ring

Material No. St 52-3 nickel-plated

Support collar

Material No. 1.4404

Inner pipe seal

Graphite ring



Type	DN	Type designation	Connection	d1 mm	L mm	Article No.
CNT 25	25	outer thread	R 1"	50.0	72	1014363
CNT 39	32	outer thread	R 1 ¼"	58.0	71	1014648
CNT 40	40	outer thread	R 1 ½"	71.2	83	1014369
CNT 50	50	outer thread	R 2"	84.7	90	1014372
CNT 100	80	outer thread	R 3"	136.0	122	1014375

Through-connection GRAPA

Compression/screwed connection

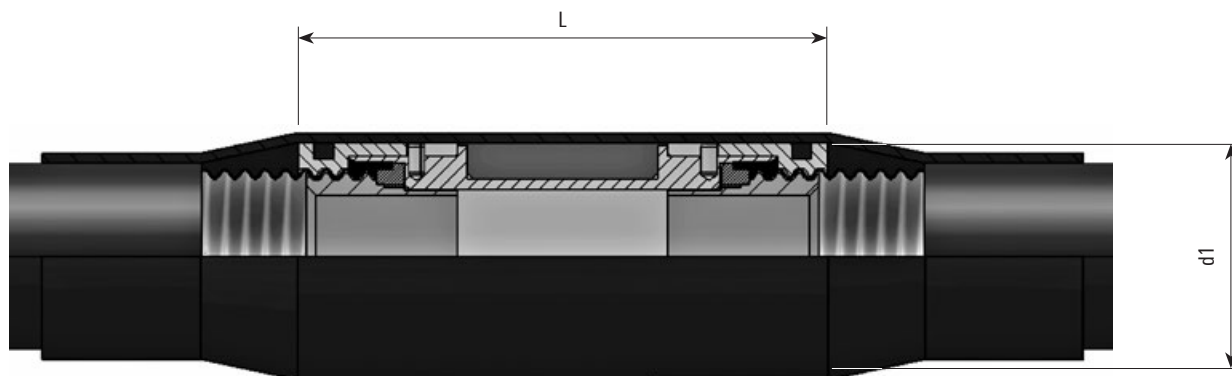

Material:

Connection piece with collar	Material No. 1.4404
Pressure ring	Material No. 1.4301
Support collar	Material No. 1.4404
Inner pipe seal	Graphite ring
Packing	PE-HD



The fitting cannot be detached after assembling.

Type	DN	d1 mm	L mm	Article No.
CNT 30/ 39	25	50.0	144	1014646
CNT 39/ 49	32	58.0	142	1014650
CNT 48/ 60	40	71.2	166	1014654
CNT 60/ 71	50	84.7	180	1014658
CNT 98/120	80	136.0	320	1014662

Steel duct and pipe sleeve entry

General information

The PETREX®-CNT steel duct entry Type SSE is designed to be used with standard-sized pipe sleeves. The pipe sleeves must be provided by the contractor.

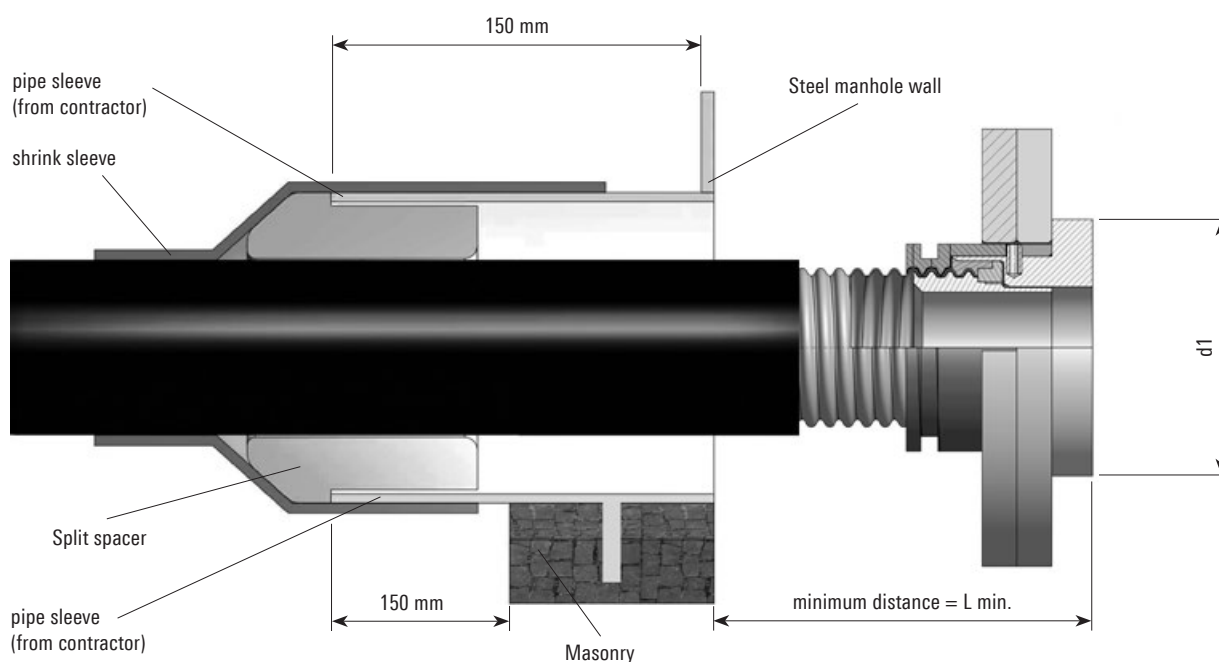

Type SSE	pipe sleeve (from contractor) mm	d1 mm	L min. mm	Article No.
CNT 30/ 39	76.1 x 2.9	68	200	1014669
CNT 39/ 49	76.1 x 2.9	68	200	1014669
CNT 48/ 60	114.3 x 3.6	88	200	1014670
CNT 60/ 71	114.3 x 3.6	102	250	1014671
CNT 98/120	168.3 x 4.5	158	250	1014672

Supplied by BRUGG: split spacer and shrink sleeve

Fluid mechanics

Pressure loss diagram for normal and high-octane petrol

Temperature: 15 °C
 Specific density: 735 kg/m³
 Kinematic viscosity: 5.5 · 10⁻⁷ m²/s

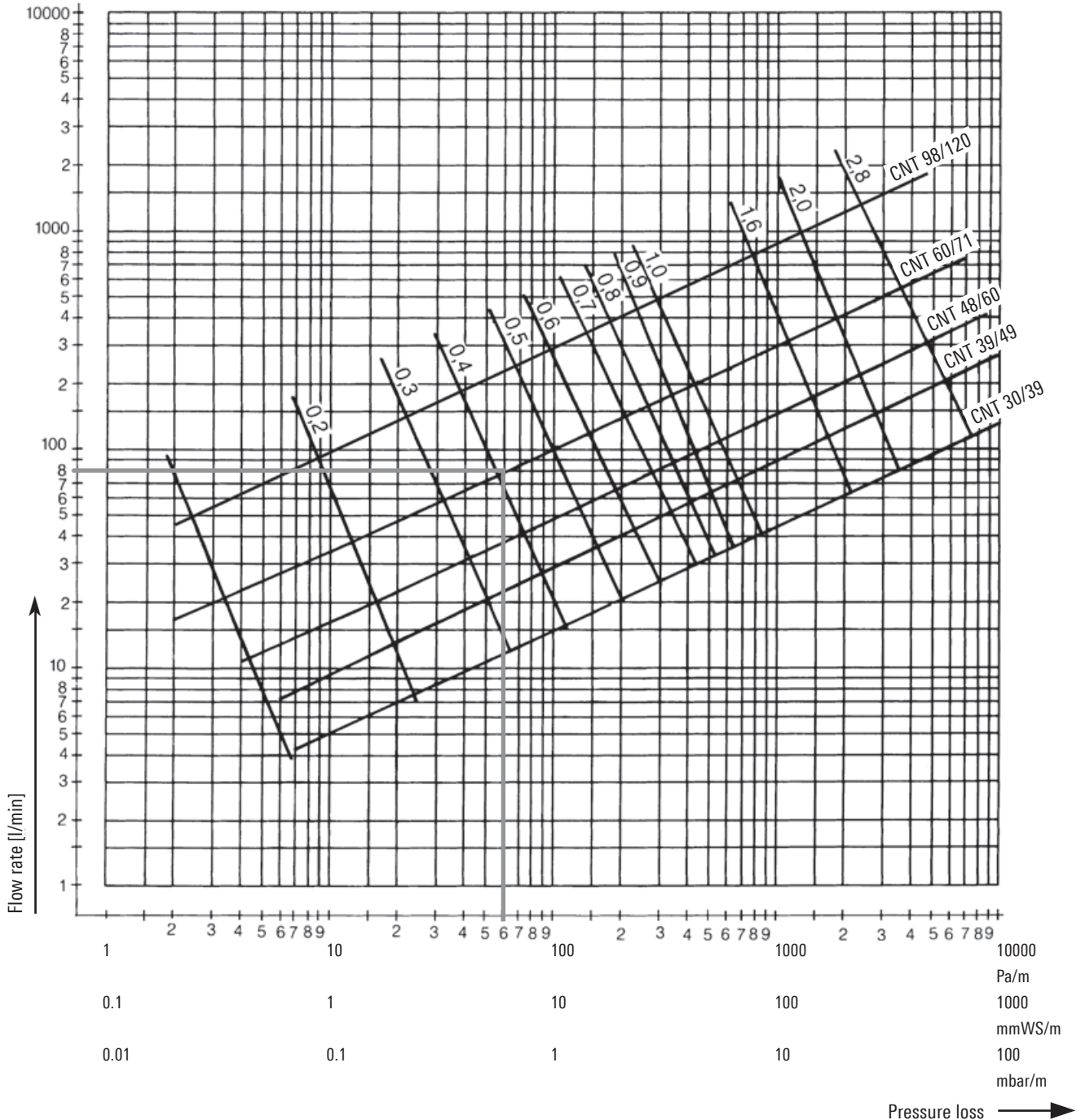

Example:

Pipe DN 50
 Flow rate 80 l/min
 at a speed of c. 0.4 m/s
 pressure loss is 0.6 mbar/m

Fluid mechanics

Pressure loss diagram for heating oil (EL) and diesel fuel

Temperature: 15 °C
 Specific gravity: 860 kg/m³
 Kinematic viscosity: 7 · 10⁻⁶ m²/s

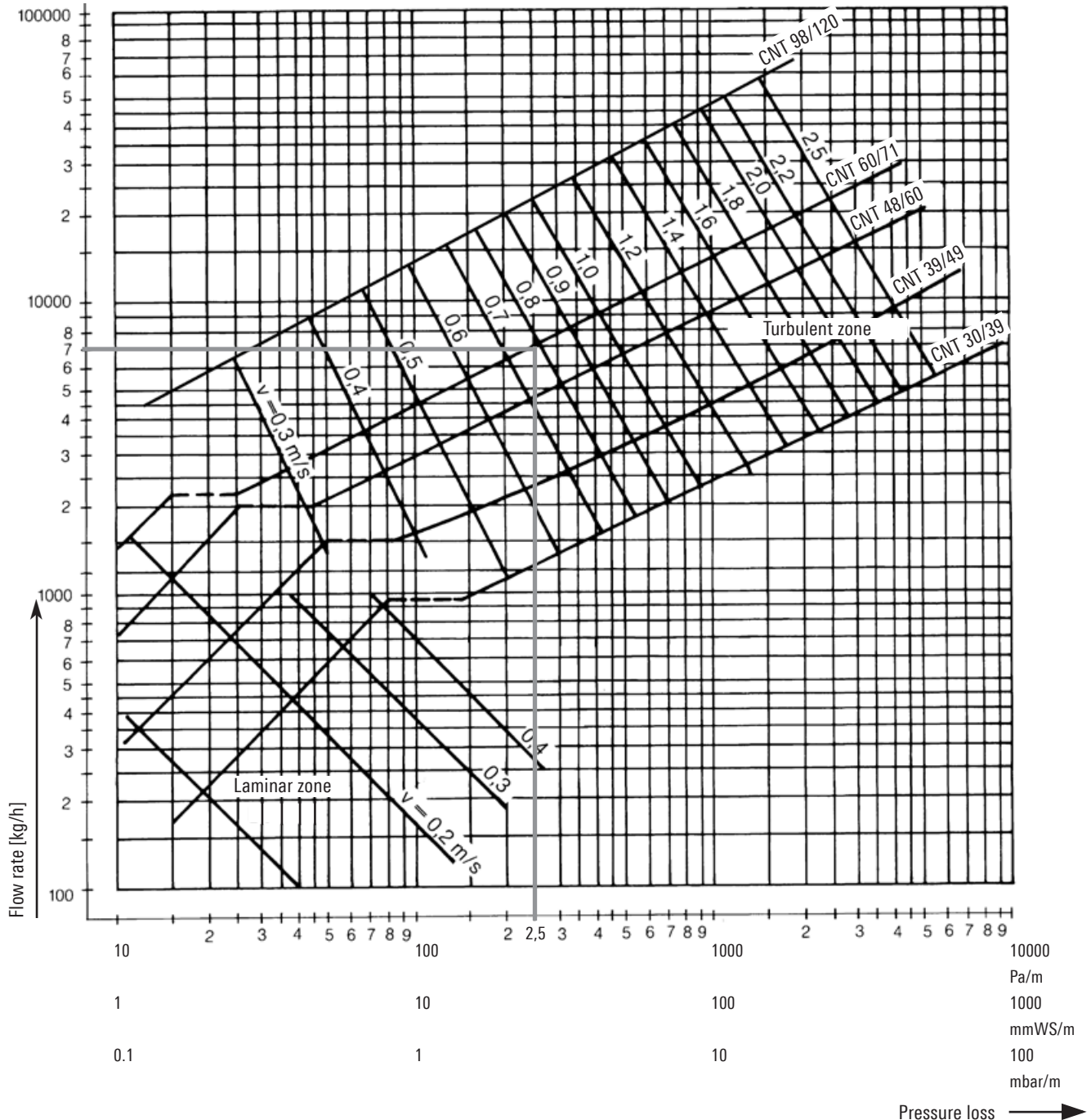

Tips for laying

for pressure/suction pipe PETREX®-CNT

Thorough preparations

The following preparations should be completed before laying commences:

- Install fuel dispenser lift hole with installation mounting to fix and restrain the piping
- Install the switching duct with mounting for the piping to be led into it
- Install the remote feed tank with fill nozzle and counter flange for installing the remote fill pipe
- Prepare the dome cover with counter flange for the piping (aligned according to the pipework drawings)
- Prepare the steel manhole with the correct pipe sleeve dimensions for leading in the piping

Preparing and levelling the soil

The PETREX®-CNT Pipe systems for petrol stations must be laid on a layer of sand bedding at least 10 cm thick. The depth of the trench bottom can be calculated by adding the height of the sand bedding to the laying depth of the suction piping. Use sand with a grain size of < 2 mm and level the sand bedding afterwards. Finally tamp down the sand to compact it.

The careful preparation of the trench bottom is essential for the fast and efficient laying of the piping.

Laying the suction pipes

The PETREX®-CNT pipe system for petrol stations is a bendable pipe system, in contrast to conventional piping. It is manufactured in one piece and wound on cable drums. The piping is laid direct from the drum into the trench on site and cut to the length needed.

Important points which must under all circumstances be observed when laying the sand bed:

- In order to guarantee the safe functioning of the pipe on the inherently safe suction principle, the piping must have a continuous downward gradient to the tank.
- When choosing the downward gradient, take care to consider any crossing pipes on your routing. The minimum gradient must be maintained under all circumstances along the entire line.
- You must make up the sand bedding in such a way that the suction piping lies directly on it all the way along when it laid later. This will prevent the pipe from sagging and forming bulges. Under no circumstances is it permissible to let the piping lie on the bedding only at certain points.
- The laying of the sand bedding must be completed before pulling in of the piping commences.

Laying the feed pipes

Unlike conventional piping, the pressure pipes are a bendable pipe system. They are manufactured in one continuous piece and wound on cable drums. The pipes are laid direct into the trench off the drum on site and cut to whatever length is needed. Due to its flexibility the pipe can be laid in one piece over great lengths.

Manual installation of pipe connections on site is only necessary at the ends of the pipe lines.

Expansion takeup

Longitudinal expansion due to temperature rise is taken up in positive pressure piping by the geometrical variation of the corrugated pipe, rather like a compensator. No action therefore needs to be taken to compensate expansion. Expansion bends as in conventional piping are not needed.

Anchor points

Anchor points are not needed when piping is laid in the ground. That means that routing can be freely chosen in this respect so that no extra work is needed.

Volume increase in fluid transport media due to temperature rise and resulting higher pressures can only be elastically compensated to a limited extent when piping is laid above ground.

Safety equipment

Positive pressure pipes must comply with TRbF 40/50. Additional approvals are in preparation here.

Notes

A large rectangular grid area for taking notes, consisting of 20 columns and 40 rows of small squares.

Notes

A large grid area for taking notes, consisting of a 30x30 grid of small squares. The grid is empty and occupies the central portion of the page.

Notes

A large rectangular area filled with a fine grid of small squares, intended for handwritten notes or technical drawings.

Pipe systems for the future

District heating – Industry – Petrol stations – System packages



Your partner for pipe systems

We are the people you should talk to when you need to find efficient solutions for transporting liquid materials. With our project engineers, development department, in-house production unit, and our professional team of fitters, we have the know-how and the resources to look after your projects competently and reliably in the sectors of heating systems, petrol station construction, industrial plant construction, and system packages.

International network

Our global partnership network can be reached on site at any time. More than 34 partners in 20 different countries will look after you wherever you are.

Customer-specific solutions

Brugg is the full service provider in the field of single-wall, double-wall and insulated pipe systems. This know-how allows us to manufacture project-specific customised items.

Give us a call!

Our engineers would be pleased to advise you and find a made-to-measure solution.

BRUGG Rohrsysteme GmbH

Adolf-Oesterheld-Straße 31
D-31515 Wunstorf
phone +49 (0)5031 170-0
fax +49 (0)5031 170-170
info.brg@brugg.com
www.brugg.de

Brugg Rohrsystem AG

Industriestrasse 39
CH-5314 Kleindöttingen
phone +41 (0)56 268 78 78
fax +41 (0)56 268 78 79
pipesystems@brugg.com
www.pipesystems.com

A company of the BRUGG Group